

[CONTRIBUTION FROM THE CHEMICAL LABORATORY OF CLARK UNIVERSITY, I, 16]

THE PREPARATION AND PROPERTIES OF TRIMETHYLSTANNANE

BY CHARLES A. KRAUS AND WILLARD N. GREER

Received August 11, 1922

Introduction.—The hydrogen derivatives of the various elements decrease in stability as we proceed from the elements of the halogen group to the elements of higher negative valence, and as we proceed from elements of lower to elements of higher atomic weight. All the elements of the halogen group give stable hydrides at ordinary temperatures. The hydrides of the higher members of the oxygen group have comparatively little stability, while in the case of the nitrogen group only nitrogen and phosphorus form comparatively stable normal hydrides. Of the fourth group of elements, carbon and silicon form stable hydrides, but the higher members form hydrides possessing little stability. It is only recently that the existence of hydrides of tin, lead and bismuth has been established.¹

If one or more of the hydrogens of a hydride is replaced by an alkyl or aryl group, the stability of the resulting compound is greatly increased over that of the hydride. Nearly all the common elements yield stable compounds of this type when all the hydrogens are substituted in this way. The metallo-organic compounds of the elements of the fourth group exhibit unusual stability, corresponding somewhat to the exceptional stability of methane, the first member of the group. The tetra-alkyl tin compounds are, on the whole, very stable substances. It might be expected, therefore, that, in the case of tin if only a portion of the hydrogens were substituted by alkyl groups, the resulting compound would exhibit a considerable degree of stability. Compounds of this type appear not to have been prepared heretofore.

In the course of an investigation of the alkyltin compounds, the reduction products of trimethyltin halides, by means of sodium in liquid ammonia, were studied. When trimethyltin chloride, for example, is treated with an excess of sodium in liquid ammonia, sodium trimethyltin, a salt-like substance, is formed quantitatively,² the reaction taking place according to the equation, $(\text{CH}_3)_3\text{SnCl} + 2\text{Na} = \text{NaCl} + (\text{CH}_3)_3\text{SnNa}$. The sodium-trimethyltin salt, which may be termed sodiumtrimethylstannide, resembles in many respects the salts of the compounds formed between the alkali metals and the triphenylmethyl group, which are properly termed methides.³ These compounds of tin are extremely reactive and they are

¹ Paneth, *Ber.*, **53**, 1710 (1920). See, also, *ibid.*, **51**, 1704, 1728 (1918); **52**, 2020 (1919); and **53**, 1693 (1920).

² Observations by Mr. W. V. Sessions in this Laboratory.

³ Schlenk and Marcus, *ibid.*, **46**, 2843 (1913); **48**, 608 (1916).

suggested as a means for the preparation of the corresponding hydrogen derivatives, namely of the tri-substituted stannanes.

If sodiumtrimethylstannide is treated with an acid in liquid ammonia, the sodium reacts with the negative ion of the acid to form a salt, and it might be expected that the hydrogen would either react with the organic tin group to form a stannane or, otherwise, that hydrogen would be evolved. The possible reactions are, therefore, as follows,

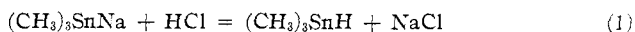

or

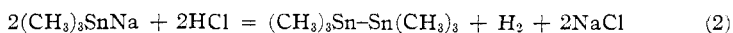

Experiment showed that reaction takes place according to the first equation.

Preparation of Trimethylstannane.—The preparation of trimethylstannane was carried out in an apparatus of the form shown in outline in the accompanying figure.

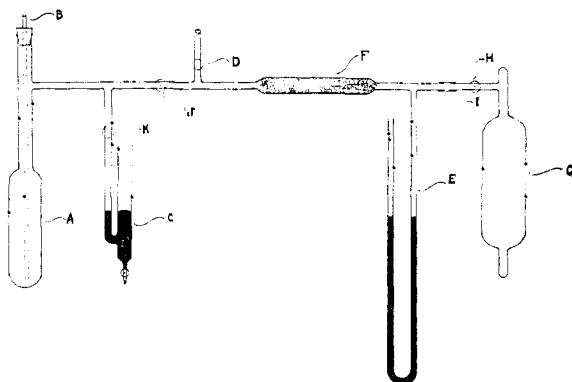

Apparatus employed in preparing trimethylstannane and in determining its vapor density.

A is the reaction tube in which the stannane is prepared. During the course of preparation, this tube is placed in a bath of boiling liquid ammonia contained in a Dewar tube. The ammonia in which the reaction is carried out is introduced through the tube B, which is attached to a cylinder containing liquid ammonia, previously dried and purified by means of metallic sodium. The ammonia is condensed in A, under a pressure of about 20 cm. of mercury in the manometer C. From 1.0 to 1.3 g. of metallic sodium is added to 10 cc. of ammonia, and to this solution very nearly $\frac{1}{2}$ of an equivalent of trimethyltin chloride is added in the form of pellets, having a weight of approximately 0.3 g. each. The solution, during the course of the reaction, is stirred by passing ammonia through the tube B from the cylinder. When the reaction is completed, ammonium nitrate is added in an amount equivalent to the original trimethyltin chloride taken. The nitrate is also added in the form of pellets. Care should be taken in adding the nitrate, since the reaction is a vigorous one. In the course of this reaction, the trimethylstannane separates at the bottom of the reaction tube as of an oily liquid. When the reaction is completed, the glass tube B is removed and the excess ammonia is drawn off by means of a jet pump. A stopper is then inserted

in the neck of the tube *A* and the trimethylstannane left behind is freed from impurities, which consist chiefly of ammonia and sodium chloride. To carry out the purification for the purpose of determining the molecular weight of the vapor of the resulting trimethylstannane, the apparatus is attached to a vacuum pump through the stopcock *D*. The apparatus is further provided with a manometer *E*, a calcium chloride tube *F* for absorbing the last traces of ammonia, and a weighing tube *G*. The weighing tube is provided with a stopcock *H* and is attached to the apparatus by means of a well-shel-lacked joint *I*. The stopcock *J* serves to separate the manometer and calcium chloride tube from the reaction tube *A*; and the manometer *C* may be shut off by means of the stopcock *K*. After stoppering the tube *A*, the stopcock *K* is closed and the stopcocks *J* and *D* are opened. Any air present in the reaction tube and the connecting tubes is pumped out. In order to remove traces of air in the connecting tubes and in the calcium chloride tube *F*, the stopcock *J* is closed at intervals and the tubes are exhausted by means of the pump. Connection is then again made with the reaction tube *A*. During the process of removing the ammonia from the trimethylstannane in the reaction tube *A*, the bath of ammonia is kept around the tube in order to reduce the vapor pressure of trimethylstannane as much as possible. When the greater portion of the ammonia has been removed, the stopcock *D* is closed and the pressure in the manometer *E* is noted. Stopcock *D* is then again opened and the trimethylstannane in the tube *K* is boiled under reduced pressure. The stopcock *J* is then closed and the connecting tubes and the manometer are again exhausted, after which *J* is again opened. The pressure is noted when the system has come to equilibrium. When the pressure indicated by the manometer *E* has reached a constant value, which amounts to a few millimeters at the boiling point of liquid ammonia, all ammonia and other foreign gases have been removed from the system.

The weighing tube *G*, having been exhausted prior to attachment to the apparatus, the stopcock *H* is opened, while the bath is removed from around the reaction tube *A*. The bottom of the weighing tube *G* is now surrounded by a bath of boiling liquid ammonia and the trimethylstannane is distilled from the reaction chamber into the weighing tube. When a considerable quantity of liquid has been collected in *G*, the bath of ammonia is removed and the contained liquid is allowed to come to the temperature of the surroundings. In general, more trimethylstannane was distilled into *G* than was required to fill the vapor space. The excess of stannane was then removed by again cooling the reaction chamber *A*. This served the purpose of removing from *G* any foreign gases that may have remained. Finally, the vapor pressure of the trimethylstannane in the weighing tube *G* is measured by means of the manometer *E*, and the temperature is noted. Thereafter, the tube is weighed and the density of the vapor determined.

Several precautions must be observed in this procedure. In the first place, it is essential that a slight excess of sodium shall be present in the reaction chamber *A*, as otherwise, if an excess of the chloride is present, it will be carried into the weighing tube *G* in the course of the distillation and, as a result, too high a value will be found for the molecular weight. On the other hand, it is necessary that all foreign gases shall be completely removed, since even a millimeter or two of pressure due to a foreign gas has an appreciable influence on the value of the density as finally determined.

Molecular Weight of Trimethylstannane.—Several preliminary determinations of the molecular weight were carried out by the method described above and results obtained corresponding to the calculated molecular weight of trimethylstannane within a few per cent. The details of the final determination are given on the following page.

Wt. of "density tube".....	27.3995 g.
Temperature 22.2°, barometric pressure 746.4 mm.	
Wt. of "density tube" evacuated.....	27.1500 g.
Wt. of contained air.....	0.2495 g.
Calc. vol. of density tube.....	212.5 cc.
Levels of mercury columns in manometer.....	796.9 mm.
	<u>165.5 mm.</u>
Diff. in levels.....	631.4 mm.
Bar. pressure.....	745.7 mm.
Pressure of the stannane vapor.....	114.5 mm.
Temp.....	22.5°
Wt. of density tube filled with stannane vapor at the above re- recorded pressure and temperature.....	27.3694 g.
Wt. of stannane vapor.....	0.2194 g.
Calc. vol. corr. to 0° and 760 mm. pressure.....	29.69 cc.
Calc. wt. of 1 liter under standard conditions of pressure and tem- perature.....	7.3897
Calc. mol. wt.....	165.53
Theoretical mol. wt.....	164.78

As may be seen from the results given above, the molecular weight as found has a value of 165.53 against the theoretical value of 164.78. There can be no question but that the compound is trimethylstannane.

Properties of Trimethylstannane.—That the product is, in fact, trimethylstannane is further borne out by the properties of the compound. When treated with metallic sodium in liquid ammonia, the compound reacts with the formation of the sodium salt and the evolution of hydrogen, according to the equation, $(\text{CH}_3)_3\text{SnH} + \text{Na} = (\text{CH}_3)_3\text{SnNa} + \frac{1}{2}\text{H}_2$.

The stannane is only slightly soluble in water. When treated with conc. hydrochloric acid, reaction occurs with the evolution of hydrogen and the formation of trimethylstannic chloride, according to the equation, $(\text{CH}_3)_3\text{SnH} + \text{HCl} = (\text{CH}_3)_3\text{SnCl} + \text{H}_2$. That the reaction actually takes place according to this equation was indicated, not only by the evolution of hydrogen, but also by the fact that the resulting chloride could readily be identified with the chloride from which the stannane was originally prepared. About 3 cc. of the stannane was condensed in a tube of 15 cm. length and of 1 cm. diameter, to which a condenser was attached. A few glass beads were placed in the bottom of this tube and a thermometer introduced. When the liquid in the tube was boiled, a value of 60° was found for the boiling point of trimethylstannane at 750.3 mm. barometric pressure.

Summary

The preparation of trimethylstannane is described. It is prepared in liquid ammonia solution according to the equation, $(\text{CH}_3)_3\text{SnNa} + \text{NH}_4\text{Cl} = (\text{CH}_3)_3\text{SnH} + \text{NaCl} + \text{NH}_3$. The sodiumtrimethylstannide is pre-

pared by the action of metallic sodium on trimethylstannic chloride in liquid ammonia solution.

The molecular weight of the stannide, as calculated from vapor density determinations, was found to be 165.53, compared with the theoretical value of 164.78.

Trimethylstannane reacts with sodium in liquid ammonia solution to form sodiumtrimethylstannide, with evolution of hydrogen. Treated with hydrochloric acid in aqueous solution, trimethylstannane yields trimethylstannic chloride and hydrogen.

The boiling point of trimethylstannane is 60°.

WORCESTER, MASSACHUSETTS

[CONTRIBUTION FROM THE LABORATORIES OF A. F. GALLUN AND SONS COMPANY]

THE TWO FORMS OF GELATIN AND THEIR ISO-ELECTRIC POINTS¹

BY JOHN ARTHUR WILSON AND ERWIN J. KERN

Received August 11, 1922

In an investigation of the degree of "plumping" of calf skin as a function of hydrogen-ion concentration, Wilson and Gallun² observed two points of minimum, one at P_H 5.1 and the other at 7.6. In view of the close relation existing between collagen and gelatin, this rather surprising discovery raised the question as to whether similar points of minimum might not occur also in the swelling of gelatin, especially since we found no mention in the literature of measurements of swelling at short intervals of change in hydrogen-ion concentration between P_H 5 and 8.

Procedure and Results

A series of buffer solutions was prepared, each member of which had a final concentration of 0.1 *M* phosphoric acid plus the amount of sodium hydroxide required to give the desired hydrogen-ion concentration as determined by the hydrogen electrode at 20°. The Sørensen values ranged from 3 to 12; 200 cc. of each solution was put into a stoppered bottle and kept in a thermostat refrigerator at 7°. After each solution had reached 7°, a small strip of high-grade gelatin of known weight was put into it. All strips were taken as nearly alike as possible and were kept in the solutions at 7° for 4 days, after which each strip was quickly blotted off and weighed. The experiment was repeated on another occasion with fresh solutions and the results were practically identical with those of the first experiment. In Table I are given the gains in weight

¹ Presented before the Leather Division at the 64th Meeting of the American Chemical Society, Pittsburgh, Penna., September 5 to 9, 1922.

² Points of Minimum Plumping of Calf Skin, *read at same meeting.*